



GOETZE PRECISION

Uncompromisingly different

YOUR PARTNER FOR SOLUTIONS

We are a multifaceted team of qualified specialists from various fields. Behind the name and title you will find one thing in particular: an individual with expertise and experience! We strive to pass on this expertise so that we can offer tailor-made solutions to our customers.

WE ARE INTERCONNECTED

Thanks to our in-house team you can be sure to reach a competent point of contact within our company. Whether you need help with product selection, the configuration of a suitable valve or urgent inquiries. You can choose to communicate by phone, email or chat and a personal consultant is available for several different languages.

WE ARE PRECISE

In order to fit all the necessary information onto the valve, we use precision laser marking technology.

WE ARE MODERN

Intelligent minds and skilled hands are the one thing – but for the manufacturing and testing processes at Goetze KG nothing beats the highest level of precision achieved through the use of high-tech equipment: the latest generation of CNC machines and modern testing and analysis technology.

WE ARE THERE WHEN YOU NEED US

Our team of consultants who come to you. Our experience and technical know-how make us your competent advisor and partner for technical solutions.

HOW TO HANDLE PRESSURE

The competence of Goetze KG Armaturen has been in demand for more than 70 years. Our wealth of experience is as broad and varied as our areas of application for our high-performance fittings.

400.000

valves sold per year "Made in Germany"

Our locations

GERMANY, LUDWIGSBURG

CHINA, RUSSIA, UNITED KINGDOM | OWN DISTRIBUTORS

-270 °C – +400 °C

uncompromising performance

0,2 BAR – 630 BAR

extensive pressure range

Goetze's concentrated expertise

We support our customers with our many years of experience in this sector at the highest level. Thanks to the expertise of our qualified development team, we are able to continuously develop new and innovative products and adapt to individual customer requirements. Using precise manual work and precision manufacturing, we are able to advance the ideas and product innovations of our customers – customer-focused, solution-oriented, flexible and always in brand quality.

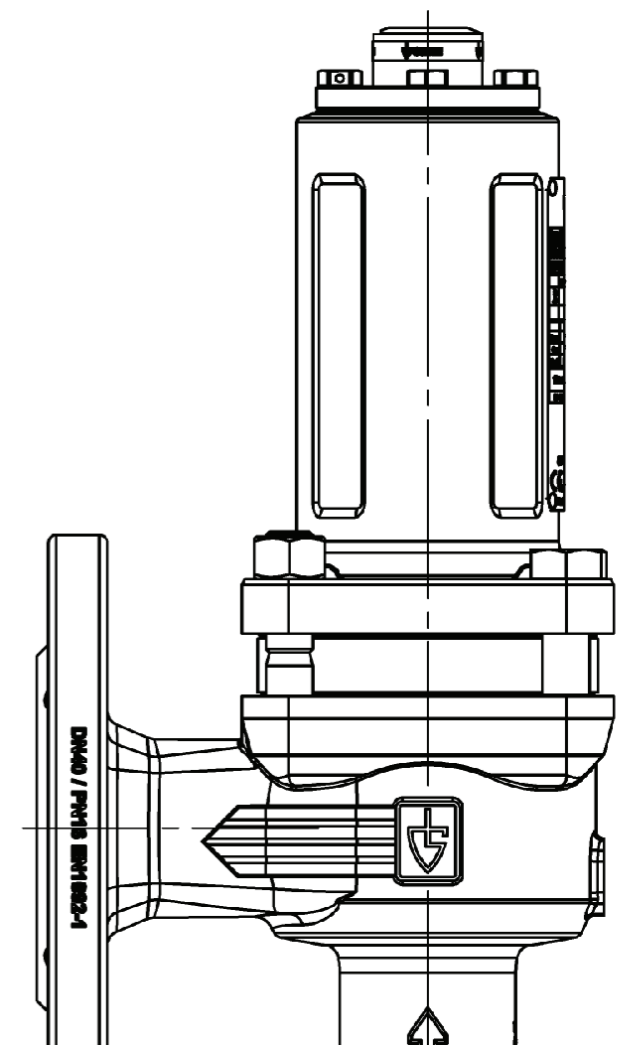

Medium-sized and family-owned

The company has been run by the family for 70 years and three generations. The competence of Goetze KG is in demand all over the world. Our product families cover a wide range of fields in industry. Manageable units, short set-up times and employees with know-how, skill and experience are what set Goetze KG apart. Not any old anonymous assembly line production. We are always proud to hear when Goetze KG is referred to as a "manufactory".



First-class: service and consultation for your valve

YOUR SATISFACTION IS OUR TOP PRIORITY

Striving for convincing quality is what drives us on. This commitment to high quality represents a cornerstone of our success. It forms the central theme throughout the Goetze KG company, from the initial idea and the selection of materials to the expertise of our employees and the quality inspection of each individual valve.



As your competent partner when it comes to handling pressure, we are always looking to improve even further and present even more product innovations for your applications. This is why we have continuously been bringing new, well thought-out solutions onto the market since 1949. The valves are developed for you with the highest level of precision and technology and are tailored to your specific needs. Yet the most important recognition for us is the satisfaction of our customers. Our employees give their all on a daily basis in order to achieve this goal.



TECHNICAL BASICS

Materials

STAINLESS STEEL



- high-quality material
- corrosion-resistant
- for plants with particularly aggressive media

GUNMETAL

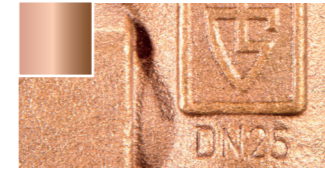

- robust and of high quality
- potable- / sea-water resistant
- wide range of applications

BRASS



- good price/performance ratio
- brass turned from solid material

SPHEROIDAL GRAPHITE CAST IRON



- robust material
- cost-effective material for standard applications

Media

LIQUIDS

from -200°C to +400°C

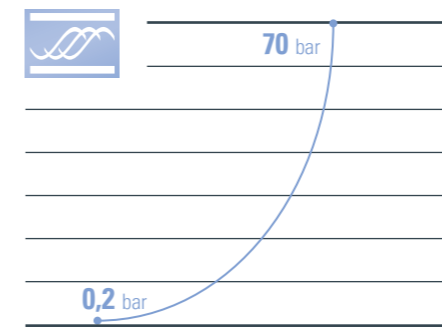

- Pump protection
- Pressure boosters (water-side)
- Sprinkler systems
- Cooling circuits

AIR, GASES AND VAPOURS

from -200°C to +400°C

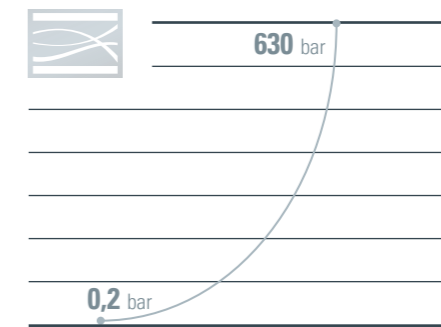

- Compressors
- Pressure vessels
- Pressure boosters (air-side)
- Silo container
- Bulk transport vehicles

STEAM

from +120°C to +400°C

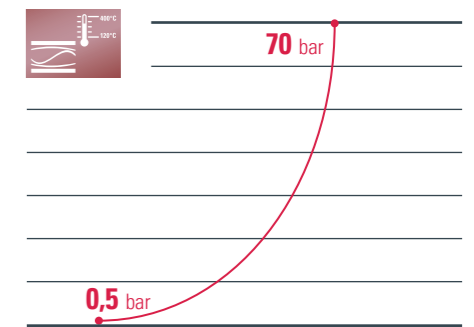

- Steam boiler
- Steam plants
- Sterilizers
- Autoclaves
- Boilers

Connections

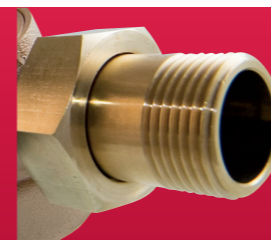

Threaded connections
1/4" to 2"

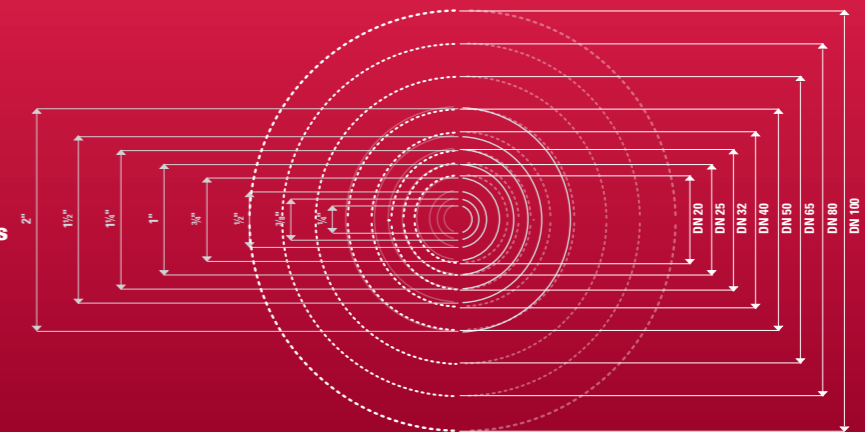
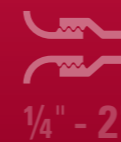

Flange connections
DN 15 to DN 100



DN 15 - DN 100

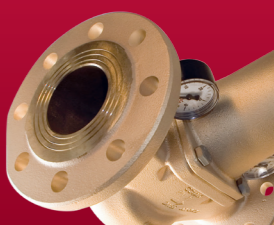

WHAT SETS GOETZE AND THEIR INDUSTRIAL PRODUCTS APART



SHORT DELIVERY TIMES AROUND THE GLOBE

Whether you need safety valves, pressure reducing valves, pressure relief valves or other products from our range: you will benefit from the short global delivery times for all our products. All orders can generally be processed within 3-5 working days. You're in a hurry? Then use our express production and your order can be ready for dispatch within 48 hours.



INDIVIDUALITY

Our expertise enables us to implement new and custom-made developments in a short time. All valves are produced on the premise of "individuality for more safety". In product development, individual custom-made solutions go hand-in-hand with our own new developments. This combined pool of development has now given rise to an extensive and high-quality range of products which is being continuously extended and leaves nothing to be desired.



WIDE RANGE OF PRODUCTS

Our well thought-out families of products cover every industrial application: liquids of all kinds, gases, technical vapours and steam. Goetze valves are used with temperatures ranging from -270 °C to +400 °C. Regardless of whether it is safety valve, pressure reduction valve, pressure relief valve or overflow valve, the greatest possible safety is always given priority.



RELIABLE COMPETENCE

Technical consulting is not only the focus of our in-house team. We provide support for our customers throughout the entire life cycle of the valve and assist those persons who have to work with the fittings every day by providing you with the necessary information and instruction. Our field representatives are tasked with providing customers with the best possible consultation service at the customer's own facility and supporting them in all questions concerning our products.



HIGH STANDARDS

Not only the products but also the materials used have to meet the highest standards. This is why the materials are examined by trained personnel as soon as they arrive, in order to ensure the best quality from the very beginning. After production, each individual valve is subjected to an ISO-certified quality control test before it is allowed to leave the factory.

OUR CERTIFICATES

We rely on quality – nationally and internationally

PROOF OF THE SAFETY AND RELIABILITY WE OFFER

CE Certification according to the European Pressure Equipment Directive is mandatory for many products and markets. Additional certificates are however proof of our individual quality, such as: TÜV, DVGW, WRAS, ACS, EAC, SINTEF. Last but not least, DIN ISO 9001 stands for the internal quality management process, with its comprehensive functionality and performance assessment. The particularly strict regulations of the national rules guarantee the highest possible degree of safety – especially when it comes to the reliability of your plant.

GENERAL TYPE TEST APPROVALS



APPLICATIONS: POTABLE WATER AND BUILDING TECHNOLOGY

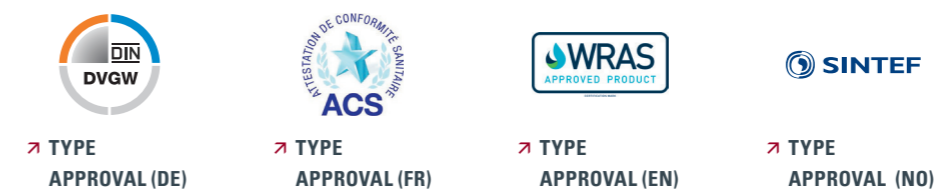

APPLICATIONS: SHIPBUILDING AND RAILWAY



QUICKFINDER CERTIFICATES

SAFETY VALVES

Series	National Type Test (TUV)	CE 2014/68/EU	EU type examination	ASME	CRN	EAC	TS	KC	ACS Potable water approval	DNV-GL	Lloyd's Register	ABS	VERITAS	Registro Italiano Navale (RINA)	DB Railway
451	■	■	■	■	■	■	■	■		■	■	■	■	■	
851	■	■	■	■	■	■	■	■		■	■	■	■	■	
460	■	■	■			■		■		■	■	■	■	■	
652	■	■	■			■		■		■	■	■	■	■	
420	■	■	■			■		■		■	■	■	■	■	
461	■	■	■			■	■	■		■	■	■	■	■	
861	■	■	■			■	■	■		■	■	■	■	■	
852	■	■	■			■		■		■	■	■	■	■	
455	■	■	■			■		■				■	■	■	
355	■	■	■			■									
642	■	■	■	■	■	■		■		■	■	■	■	■	
645	■	■	■	■	■	■		■		■	■	■	■	■	
6420	■	■	■	■	■	■		■							
6450	■	■	■	■	■	■		■							
410	■	■	■	■	■	■	■	■		■	■	■	■	■	
810	■	■	■	■	■	■	■	■		■	■	■	■	■	■
412	■	■	■	■	■	■	■	■		■	■	■	■	■	
812	■	■	■	■	■	■	■	■		■	■	■	■	■	■
413	■	■	■			■	■	■		■	■	■	■	■	
813	■	■	■			■	■	■		■	■	■	■	■	
492	■	■	■	■	■	■	■	■		■	■	■	■	■	

PRESSURE RELIEF VALVES

Series	CE 2014/68/EU	EAC	DNV-GL	Lloyd's Register	ABS	VERITAS	Registro Italiano Navale (RINA)
628	■						
601	■	■					
612	■	■					

OVERFLOW AND PRESSURE CONTROL VALVES

Series	CE 2014/68/EU	EAC	DNV-GL	Lloyd's Register	ABS	VERITAS	Registro Italiano Navale (RINA)
417	■	■	■	■	■	■	■
418	■	■	■	■	■	■	■
617	■	■	■	■	■	■	■
618	■	■	■	■	■	■	■
453	■	■	■	■	■	■	■
853	■	■	■	■	■	■	■
630	■	■	■	■	■	■	■
430	■	■	■	■	■	■	■
431	■	■	■	■	■	■	■
631	■	■	■	■	■	■	■

HYGIENIC VALVES

Series	National Type Test (TUV)	CE 2014/68/EU	EU type examination	ASME	CRN	EAC	TS	KC	DNV-GL	Lloyd's Register	ABS	VERITAS	Registro Italiano Navale (RINA)	CERTIFIED CHEDG
Hygienic 400	■	■	■			■	■	■	■	■	■	■	■	■
Hygienic 400.5		■				■			■	■	■	■	■	
Hygienic 4000	■	■	■	■	■	■	■	■	■	■	■	■	■	

PRESSURE REDUCING VALVES

Series	CE 2014/68/EU	EAC	DNV-GL	ACS	WRAS	SINTEF	DNV-GL	Lloyd's Register	ABS	VERITAS	Registro Italiano Navale (RINA)
481	■	■	■	■	■		■	■	■	■	■
681	■	■	■	■	■	■	■	■	■	■	■
482	■	■	■	■	■		■	■	■	■	■
682	■	■	■	■	■		■	■	■	■	■
683	■	■					■	■	■	■	■
484	■	■						■	■	■	■
684	■	■					■	■	■	■	■

QUICKFINDER VALVES

TYPE TEST APPROVED SAFETY VALVES ANGLE TYPE

Series	Materials	Connection type	Media						Temperature in °C	Set pressure bar
			neutral			non-neutral				
			liquid	air/gases	steam	liquid	Air/gas	steam		
451			■	■	■	■	■	■	■	
851			■	■	■	■	■	■	■	
460			■	■	■	■	■	■	■	
652			■	■	■	■	■	■	■	
420			■	■	■	■	■	■	■	
461			■	■	■	■	■	■	■	
861			■	■	■	■	■	■	■	
852			■	■	■	■	■	■	■	
455			■	■	■	■	■	■	■	
355			■	■	■	■	■	■	■	
642			■	■	■	■	■	■	■	
645			■	■	■	■	■	■	■	
6420			■	■	■	■	■	■	■	
6450			■	■	■	■	■	■	■	

TYPE TEST APPROVED ATMOSPHERIC DISCHARGE SAFETY VALVES

Series	Materials	Connection type	Media						Temperature in °C	Set pressure bar
			neutral			non-neutral				
			liquid	air/gases	steam	liquid	air/gases	steam		
410			■	■	■	■	■	■	■	
810			■	■	■	■	■	■	■	
412			■	■	■	■	■	■	■	
812			■	■	■	■	■	■	■	
413			■	■	■	■	■	■	■	
813			■	■	■	■	■	■	■	

TYPE TEST APPROVED ATMOSPHERIC DISCHARGE SAFETY VALVES FOR HIGH PRESSURE RATINGS

Series	Materials	Connection type	Media						Temperature in °C	Set pressure bar
			neutral			non-neutral				
			liquid	air/gases	steam	liquid	air/gases	steam		
492			■	■	■	■	■	■	■	
492GOX			■	■	■	■	■	■	■	

PRESSURE RELIEF VALVES

Series	Materials	Connection type	Media						Temperature in °C	Set pressure bar
			neutral			non-neutral				
			liquid	air/gases	steam	liquid	air/gases	steam		
628			■	■	■	■	■	■	■	
601			■	■	■	■	■	■	■	
612			■	■	■	■	■	■	■	

OVERFLOW AND PRESSURE CONTROL VALVES

Series	Materials	Connection type	Media						Temperature in °C	Set pressure bar
			neutral			non-neutral				
			liquid	air/gases	steam	liquid	air/gases	steam		
417			■	■	■	■	■	■	■	
418			■	■	■	■	■	■	■	
617			■	■	■	■	■	■	■	
618			■	■	■	■	■	■	■	
453			■	■	■	■	■	■	■	
853			■	■	■	■	■	■	■	
430			■	■	■	■	■	■	■	
431			■	■	■	■	■	■	■	
630			■	■	■	■	■	■	■	
631			■	■	■	■	■	■	■	

SAFETY FITTINGS FOR HYGIENIC APPLICATIONS

Series	Materials	Connection type	Media						Temperature in °C	Set pressure bar
			neutral			non-neutral				
			liquid	air/gases	steam	liquid	air/gases	steam		
400			■	■	■	■	■	■	■	
400.5			■	■	■	■	■	■	■	
4000			■	■	■	■	■	■	■	

PRESSURE REDUCING VALVES

Series	Materials	Connection type	Media						Temperature in °C	Set pressure bar
			neutral			non-neutral				
			liquid	air/gases	steam	liquid	air/gases	steam		
481			■	■	■	■	■	■	Inlet pressure Outlet pressure	
681			■	■	■	■	■	■	Inlet pressure Outlet pressure	
482			■	■	■	■	■	■	Inlet pressure Outlet pressure	
682			■	■	■	■	■	■	Inlet pressure Outlet pressure	
683			■	■	■	■	■	■	Inlet pressure Outlet pressure	
484			■	■	■	■	■	■	Inlet pressure Outlet pressure	
684			■	■	■	■	■	■	Inlet pressure Outlet pressure	

TYPE TEST APPROVED SAFETY VALVES ANGLE-TYPE

Materials



Temperatures
from -270°C to +400 °C



Pressures
from 0,2 bar to 70 bar

Media



Threaded connections
from ¼" to 2"



Flange connections
from DN 15 to DN 100

No matter what media our customers use – our comprehensive product range covers practically every application. Hereby, the sealing materials play a particularly important role: These can be selected not only according to their suitability for a very wide variety of media – even aggressive ones – but also for thermal loads up to 400 °C.

ANGLE-TYPE SAFETY VALVES ARE USED HERE:



Plant engineering



Pressure vessels in shipbuilding



Steam generators



Power generation



Type test approved safety valves angle-type

SAFETY VALVES SERIES 451

made of stainless steel, angle-type
with threaded connections



The benefits and applications of this series made of high-alloyed stainless steel begin, where versions made of gunmetal are at their limits.

The flexibility of the various versions offer the optimal configuration for every application. In addition to the basic version the numerous sealing possibilities and materials, back-pressure compensating metal bellows and/or a gastight cap offer the necessary optional extras required to fulfill the highest safety requirements.

SAFETY VALVES SERIES 851

made of gunmetal, angle-type
with threaded connections



A proven series with an extremely compact design: with its very good price/performance ratio this valve has been proving its reliability for many years. In addition to the flexible basic version, according to the version and sealing material in question, this valve can be used for a varied range of applications, media and temperatures. As an optional extra, these valves can be fitted with metal bellows and/or a gastight cap.

Consequently, these valves can be configured for applications involving non-neutral, inflammable, toxic and viscous media.

SAFETY VALVES SERIES 460

made of stainless steel, angle-type
with threaded connections



If the high capacity safety valves with their numerous feature variations for standard applications are technically too complex and oversized from a capacity point of view, but a particular emphasis is placed on quality and corrosion resistance, this stainless steel all-round talent is the perfect solution.

Whether with or without lifting device, the gas tightness of the spring housing is always guaranteed.

SAFETY VALVES SERIES 652

made of gunmetal, angle-type
with threaded connections

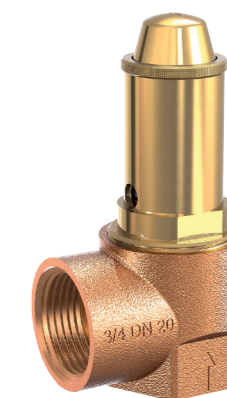

This safety valve made of gunmetal is an economical alternative to high-performance safety valves, in cases where only small blow-off capacities are required.

The version 652mFK for neutral liquids is ideal for the protection of pumps and pressure vessel systems, in cases where boiling point is never reached or if no evaporation of the media can occur. A diaphragm protects the moving parts and compression spring against the Media. The version without diaphragm, type 652sGK is ideal for protecting small compressed air systems. Depending on the sealing material, this valve can be used for neutral, non-toxic compressible media with varying temperatures.

Fitted with an EPDM seal, this can be used for steam boilers with a volume of less than 10 liters up to a set pressure of 3 bar.

 **Temperatures**
from -60 °C to +400 °C

 **Pressures**
from 0,5 bar to 70 bar

 **Threaded connections**
from 1/2" to 2"



Data sheet

 **Temperatures**
from -60 °C to +225 °C

 **Pressures**
from 0,5 bar to 50 bar

 **Threaded connections**
from 1/2" to 2"



Data sheet

 **Temperatures**
from -60 °C to +225 °C

 **Pressures**
from 0,2 bar to 25 bar

 **Threaded connections**
from 3/8" to 1"



Data sheet

 **Temperatures**
from -60 °C to +200 °C

 **Pressures**
from 1 bar to 16 bar

 **Threaded connections**
from 1/2" to 2"



Data sheet

Type test approved safety valves angle-type

SAFETY VALVES SERIES 420

made of stainless steel, angle-type
with threaded connections



These angle-type safety valves are available for the first time with TÜV and European component approval. This allows the use of tested and approved quality on the smallest pressure tanks and small steam boilers with neutral and non-neutral gas and liquid medias. The cutting ring threaded connections available as an option make this valve quick and easy to install for use in small pipelines.

SAFETY VALVES SERIES 461

made of stainless steel, angle-type
with threaded connections



The consequential expansion of the valve series 451 with smaller nominal diameters now allows the best and therefore most efficient design of safety valves with smaller discharge volumes.

The proven versatility in different variations leads to use for a variety of media with different aggregate conditions. The possibilities for use are in medical process equipment construction and in the food, beverage, pharmaceutical and cosmetics industries in secondary areas.



Temperatures
from -40 °C to +260 °C



Pressures
from 0,5 bar to 50 bar



Threaded connections
from 1/4" to 3/8"



Data sheet



Data sheet

SAFETY VALVES SERIES 861

made of gunmetal, angle-type
with threaded connections



Efficiency was the main focus of this development. For the optimum protection of small steam generators, smaller sterilisers and autoclaves, compact and component tested safety valves in increasingly smaller nominal diameters are required in many cases. The tried and tested and versatile 851 series was therefore extended with additional smaller nominal diameters to meet the demands of the market.



Temperatures
from -60 °C to +225 °C



Pressures
from 0,5 bar to 50 bar



Threaded connections
from 1/4" to 1/2"



Data sheet

SAFETY VALVES SERIES 852

made of gunmetal,
angle-type with flange connections

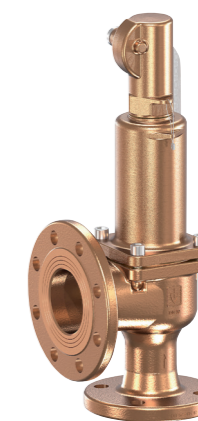

This safety valve range is also completely made of corrosion-resistant materials. The body is made of gunmetal and the stainless steel spring and internal parts, which are made of stainless steel, are hard to beat in terms of corrosion-resistance, especially when confronted with aggressive watery solutions, salt water or a saline atmosphere.

The best possible version is available for virtually every application imaginable, whether this requires metal to metal sealing to meet highest tightness requirements or a metal supported o-ring seal made of a variety of materials or even back-pressure compensating gastight metal bellows or a gastight spring housing.



Temperatures
from -60 °C to +225 °C



Pressures
from 0,5 bar to 25 bar



Flange connections
DN 40 and DN 50



Data sheet

Type test approved safety valves angle-type

SAFETY VALVES SERIES 355

made of spheroidal graphite cast iron, angle-type with flange connections



The series of flanged safety valve 355 captivates with its consistent concept of capacity, function and design. The high capacity of the entire series from DN 15 up to DN 100 is unique in the sector of flanged safety valves. Using spheroidal graphite cast iron for the housing allows a particularly inexpensive variant to be produced.

This is of particular interest for applications with heating water and steam as well as lower requirements with regard to high corrosion resistance. This series can be supplied either with open or closed cap. The range of variants is further extended by offering bellows in either elastomer or stainless steel and either a metal or soft-sealing valve seal.

SAFETY VALVES SERIES 455

made of stainless steel, angle-type with flange connections



The series of flanged safety valve 455 captivates with its consistent concept of capacity, function and design. The high capacity of the entire series from DN 15 up to DN 100 is unique in the sector of flanged safety valves. By using exclusively high-quality materials with outstanding media resistance and the option to secure the tightness towards the atmosphere on a high level with a backpressure compensating bellows, this safety valve is suitable for nearly all applications. The pressure range extends from 0.2 to 40 bar and also extremely high temperatures can be applied up to a limit of 400 °C.

SAFETY VALVES SERIES 642 AND 645

made of gunmetal, angle-type with threaded connections and flange connections

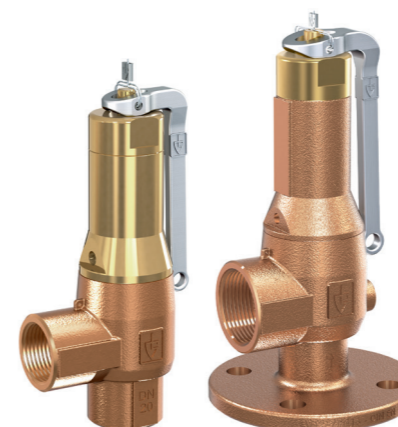

The safety valves made from gunmetal are designed to protect pressure tanks and pressure systems for neutral and non-neutral vapours, gases and liquids.

These series are also used in steam boilers and steam plants with due consideration of plant-specific regulations and in combination with suitable valve designs and sealing materials.

The areas of application of these multi-purpose safety valves with separating diaphragm between the housing and cap range from heating and air conditioning technology to mechanical engineering, boiler construction and ship building.

SAFETY VALVES SERIES 6420 AND 6450

made of gunmetal, angle-type with threaded connections and clamp connections

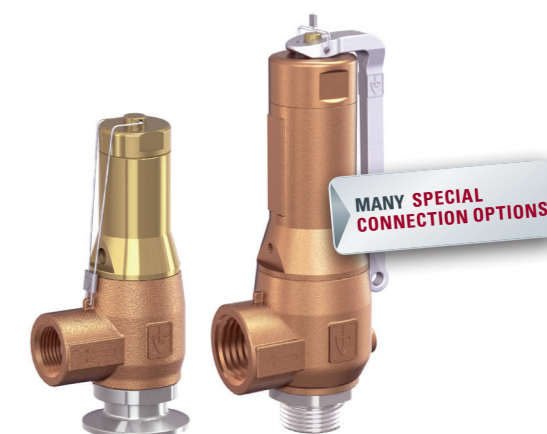

The technical features of the valve series 642 and 645 form the basis of the extended product range in which connection flexibility and corrosion resistance are paramount. The two-piece construction of the valve housing allows many different connection types to be used on the valve inlet.

The inlet nozzles and the inner parts coming into contact with the media are made from highly corrosion-resistant stainless steel, which enables the valves to be used in an even wider range of applications.

 **Temperatures**
from -10°C to +350 °C

 **Pressures**
from 0,2 bar to 40 bar

 **Flange connections**
from DN 15 to DN 100



Data sheet

 **Temperatures**
from -60°C to +400 °C

 **Pressures**
from 0,2 bar to 40 bar

 **Flange connections**
from DN 15 to DN 100



Data sheet

 **Temperatures**
from -50°C to +205 °C

 **Pressures**
from 0,5 bar to 16 bar

 **Threaded connections**
from ½" to 2 ½"

 **Flange connections**
from DN 25 to DN 65



Data sheet



Data sheet

 **Temperatures**
from -50°C to +205 °C

 **Pressures**
from 0,5 bar to 16 bar

 **Threaded connections**
from ½" to 2"



Data sheet



Data sheet

TYPE TEST APPROVED ATMOSPHERIC DISCHARGE SAFETY VALVES

Materials



Temperatures
from -60 °C to +225 °C



Pressures
from 0,2 bar to 630 bar

Media



Threaded connections
from ¼" to 2"

Through new innovations in our range of high performance safety valves for air, we are continually expanding our product range and setting new standards in the field of safety. These innovative new developments of atmospheric discharge safety valves are particularly suitable for the protection of compressors, air-receivers and bulk transport vehicles.

ATMOSPHERIC DISCHARGE SAFETY VALVES ARE USED HERE:



Bulk transport vehicles

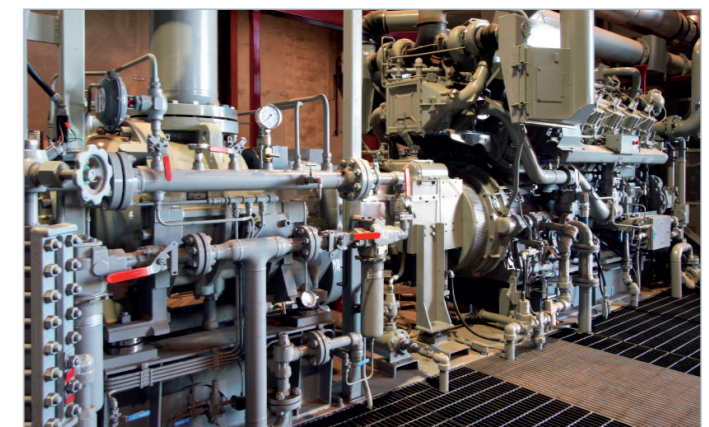

Compressors



Tank manufacturing



Pantographs



Type test approved atmospheric discharge safety valves

SAFETY VALVES SERIES 410

made of stainless steel, atmospheric discharge, with threaded connection



Our smallest and most compact compressed air safety valve with enormous blow-off capacity, so that high-performance compressors can be protected. This safety valve is also ideally suited for the protection of large stainless steel pressure vessels and air systems made of stainless steel in aggressive environments or in secondary areas in the food-, beverage-, pharmaceutical- and cosmetics industries.



Temperatures
from -60°C to +225°C



Pressures
from 0,2 bar to 50 bar



Threaded connections
from 1/4" to 1"



Data sheet

SAFETY VALVES SERIES 810

made of brass, atmospheric discharge, with threaded connection



The basic model within the range of small safety valves for compressed air. It is compact and due to its good blow-off capacities is particularly suitable for the protection of pressure vessels and compressors. However, even for large pressure vessels this valve can be employed due to its excellent price/performance ratio. This valve is equipped as standard with a stainless steel spring and FPM seal.



Temperatures
from -60°C to +225°C



Pressures
from 0,2 bar to 50 bar



Threaded connections
from 1/4" to 1"



Data sheet

SAFETY VALVES SERIES 412

made of stainless steel, atmospheric discharge, with threaded connection



This high performance safety valve made of stainless steel is unique in its class. Its slim and elegant exterior conceals the highest level of precision and performance. At the same time, this valve can be ordered with a set pressure up to 50 bar. It is suitable for air and gases which can be freely discharged into the environment.



Temperatures
from -60°C to +225°C



Pressures
from 0,2 bar to 50 bar



Threaded connections
from 1/2" to 2"



Data sheet

SAFETY VALVES SERIES 812

made of brass, atmospheric discharge, with threaded connection



The basic model within the range of high performance safety valves. Up to date technology and highest precision, high-quality components such as a stainless spindle and spring fitted into a slender body made of brass. This valve is suitable for air and gaseous media up to a set pressure of 50 bar, which can be freely discharged into the atmosphere.



Temperatures
from -60°C to +225°C



Pressures
from 0,2 bar to 50 bar



Threaded connections
from 1/2" to 2"



Data sheet

SAFETY VALVES SERIES 413

made of stainless steel, atmospheric discharge, with threaded connection



The discharge of air from pressure vessels filled with liquid, granular or powdery media requires additional safety precautions with so-called "FKS" safety valves. This valve is fitted with a weather shroud and all moving or guided parts as well as the spring housing are protected against soiling.

This makes this valve suitable for the rough conditions on bulk transport vehicles or stationary silos.



Temperatures
from -60°C to +225°C



Pressures
from 0,2 bar to 6 bar



Threaded connections
from 1/2" to 2"



Data sheet

Type test approved atmospheric discharge safety valves

SAFETY VALVES SERIES 813

made of brass, atmospheric discharge,
with threaded connection



All aspects and special safety features of the "FKS" valves made of stainless steel have been fully implemented in this series. However all technical and safety features are contained in a brass body.

These valves are an optimal solution with respect to their price/performance ratio for use on bulk transport vehicles and stationary silos. Standard version with weather shroud, stainless steel spring and FPM (Viton) seal.

SAFETY VALVES SERIES 492

made of stainless steel, atmospheric discharge,
with threaded connection

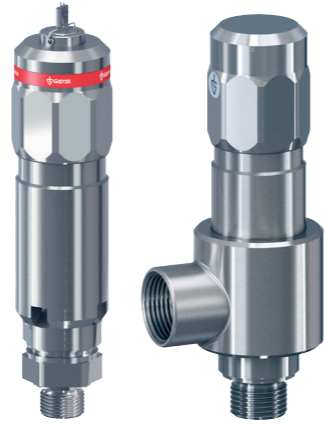

A safety valve which impresses with its small dimensions and design for the protection of high-pressure air systems and high-pressure compressors. Can optionally be ordered with a gas-tight rotatable angled housing for guided flow-off or for connecting a discharge pipe for non-neutral gaseous media.

Through its special technical construction and design the series covers a pressure range that has not been catered for up to now.

SAFETY VALVES SERIES 492 GOX

made of brass, atmospheric discharge,
with threaded connection





Safety valves specially used for applications with oxygen are needed in multiple industries. Particularly in the production of technical gases, medical gases, by compressor manufacturers as well as component manufacturers and plant manufacturers.

The high-pressure safety valve is equipped with an outlet housing which can be adjusted by 360° and is suitable for gaseous oxygen, oxygen mixtures and gases. A special property of the Goetze safety valve 492GOX is that it was explicitly inspected and approved for oxygen with adiabatic pressure shocks in a range between 50 bar and 420 bar at 60 °C.

The compact design and the rotating outlet with threaded connection allowing for adjusting the valve's discharge angle even after installation make the safety valve 492GOX an innovative gain in the Goetze product portfolio.

 **Temperatures**
from -60°C to +225°C

 **Pressures**
from 0,2 bar to 6 bar

 **Threaded connections**
from 1/2" to 2"



Data sheet

 **Temperatures**
from -60°C to +180°C

 **Pressures**
from 50 bar to 630 bar

 **Threaded connections**
from 1/4" to 3/4"



Data sheet

 **Temperatures**
from -40°C to +60°C

 **Pressures**
from 50 bar to 420 bar

 **Threaded connections**
from 1/4" to 3/4"



Data sheet



Production process for oxygen applications

The safety valve 492GOX covers a wide range of applications in the area of oxygen. These valves are used above all in the production of technical and medical gases as well as by compressor manufacturers and plant manufacturers.

When handling oxygen, the greatest care has to be taken throughout the entire production process. Only then can dangers be avoided in these applications. In order to meet these high standards, at Goetze we have a separate production process designed especially for oxygen valves. Assembly takes place in a cleanroom that is separate from the rest of the production facility. The air in this room is subjected to overpressure of 20 millibars and is filtered and conditioned. This also prevents any particles or dirt from entering from the outside.

Qualified and trained staff, compliance with all relevant codes and regular process monitoring of oil and grease-free cleaning, installation, inspection, packaging and labelling grant customers an oxygen-suitable safety valve for their applications.



PRESSURE RELIEF VALVES

Materials



Temperatures
from -60 °C to +225 °C



Pressures
from 0,1 bar to 20 bar

Media



Threaded connections
from 3/8" to 2"

Pressure relief valves are suitable for equipment which does not fall under the Pressure Equipment Directive and in cases where only small blow-off capacities are required. In addition, due to their large setting ranges per spring, they are ideally suited to be held in stock for various applications and set pressures. The set pressure can be set and altered by the user.

PRESSURE RELIEF VALVES ARE USED HERE:



Fuel system



Beverage industry

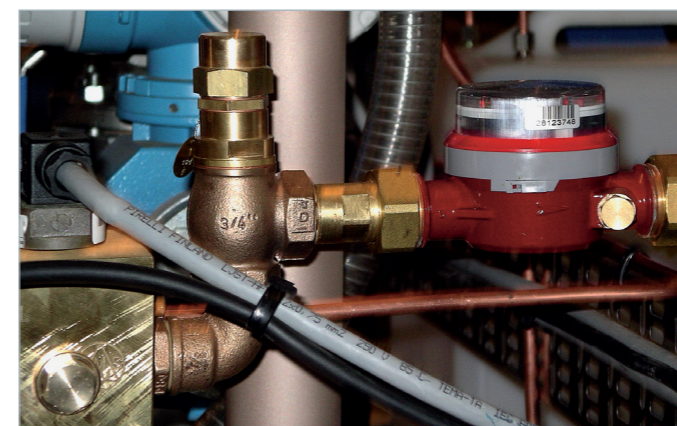

Laboratory



Pumps

Pressure relief valves

PRESSURE RELIEF VALVES SERIES 618

made of gunmetal, angle-type,
with threaded connections



With proportional opening characteristics and even larger setting ranges of the springs, this valve is ideally suited in cases where a stock value for various applications and set pressures is required and the valve needs to be readily available.

It is designed in particular for plants in which only low amounts of expansion medium have to be discharged.

PRESSURE RELIEF VALVES SERIES 628

made of gunmetal, angle-type,
with threaded connections

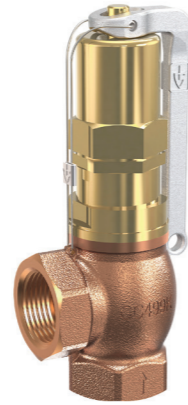

A proven all-round valve with proportional opening characteristics and an extremely compact design. In addition to the basic version, these valves are also available for the most varied customer requirements as a gas-tight version or with lifting lever. The various sealing materials available mean that this valve is suitable for a wide range of media and temperatures.

As a closed, gas-tight version without lifting mechanism it is suitable for many types of media. This makes this series an economically interesting alternative for plants which do not require any approval or which do not fall under the pressure equipment directive (PED).

 **Temperatures**
from -60°C to +225°C

 **Pressures**
from 0,2 bar to 20 bar

 **Threaded connections**
from 3/8" to 2"

 **Temperatures**
from -60°C to +225°C

 **Pressures**
from 0,2 bar to 20 bar

 **Threaded connections**
from 3/8" to 2"



Data sheet

PRESSURE RELIEF VALVES SERIES 601

made of gunmetal, with lever and weight,
angle-type with threaded connections

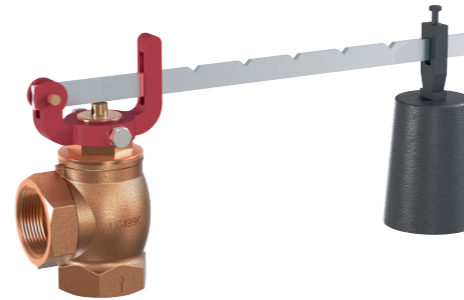

This angle-type pressure relief valve with lever and weight is an ideal alternative when in the case of low capacities a TÜV type tested valve is not necessary. The set pressure can be very easily adjusted by the user. Provided the valve is used correctly, its simple and robust design guarantee a high degree of reliability.

The valve is ideal for the protection of pressure tanks/systems for neutral vapours, gases and liquids as well as for steam boilers and steam plants, provided that proportional characteristics are desired and only small blow-off capacities are required (e.g. protection of the expansion due to heating).

 **Temperatures**
from -60°C to +225°C

 **Pressures**
from 1,5 bar to 16 bar

 **Threaded connections**
from 1/2" to 2"



Data sheet

PRESSURE RELIEF VALVES SERIES 612

made of gunmetal, with double lever and weights,
angle-type with threaded connections

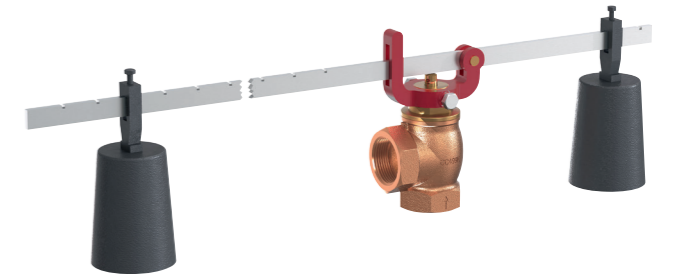

This angle-type pressure relief valve with double lever and weights offers precise protection against overpressure in the case of low set pressures.

This is a versatile alternative if the system to be protected does not fall under the pressure equipment directive and a compact version is not necessary. The set pressure can be very easily adjusted by the user. The pressure relief valve is used above all in low-pressure steam plants, low-pressure industrial applications and large boiler plants.

 **Temperatures**
from -60°C to +225°C

 **Pressures**
from 0,1 bar to 4 bar

 **Threaded connections**
from 1/2" to 2"



Data sheet



OVERFLOW AND PRESSURE CONTROL VALVES

Materials



Temperatures
from -60 °C to +225 °C



Pressures
from 0,2 bar to 30 bar

Media



Threaded connections
from 3/8" to 2"



Flange connections
from DN 15 to DN 100

These overflow and pressure control valves with proportional opening and closing characteristic are particularly suitable for test rigs, pump circuits or as pressure control or pressure relief valves. They are usually used to protect an existing pump in a closed-circuit from overloading and overheating. The media can then circulate through the bypass system of the pump or through the piping network.

OVERFLOW AND PRESSURE CONTROL VALVES ARE USED HERE:



Wind turbines



Workboats



De-icing technology



Water treatment

Overflow and pressure control valves

OVERFLOW AND PRESSURE CONTROL VALVES SERIES 417

made of stainless steel, angle-type with threaded connections



If the 617 series made of gunmetal and brass cannot be used due to an aggressive media or an aggressive environment, the new 417 series made of highly corrosion resistant stainless steel provides a solution. The sealed and gas-tight design covers an even wider application range.

The valves can be conveniently adjusted or aligned using the external adjustment, which means that perfect alignment to the operating conditions of the system is possible. They can, however, also be set and sealed at the factory.

 **Temperatures**
from -60°C to +225°C

 **Pressures**
from 0,2 bar to 20 bar

 **Threaded connections**
from 3/8" to 2"



Data sheet

OVERFLOW AND PRESSURE CONTROL VALVES SERIES 418

made of stainless steel, angle-type with threaded connections



Highly corrosion-resistant overflow valve – closed, gastight version. This is suitable for all media and due to its large spring range is suitable for a wide range of applications. Therefore it is also ideally suitable, when a customer wants to stock a valve suitable for a wide range of applications and varying set pressures. This valve is particularly maintenance-friendly due to an easily replaced valve cartridge. The valve can also be easily set or adjusted during operation.

 **Temperatures**
from -60°C to +225°C

 **Pressures**
from 0,2 bar to 30 bar

 **Threaded connections**
from 3/8" to 1 1/4"



Data sheet

OVERFLOW AND PRESSURE CONTROL VALVES SERIES 617

made of gunmetal, angle-type, with threaded connections



By means of an external setting mechanism this valve can be set or adjusted by the operator during operation. The closed, gastight version with large spring ranges offers a wide range of application possibilities. This valve is also widely used as an overflow valve in applications where the plant pressure often changes.

Due to its versatility and large spring ranges, this valve can be highly recommended as a stock item.

 **Temperatures**
from -60°C to +225°C

 **Pressures**
from 0,2 bar to 20 bar

 **Threaded connections**
from 3/8" to 2"



Data sheet

OVERFLOW AND PRESSURE CONTROL VALVES SERIES 618

made of gunmetal, angle-type, with threaded connections



Robust, proportional overflow valve – gastight version. Allround overflow valve for pump protection and bypass control applications, due to its compact design, possibility of user-adjustment within the spring ranges as well as various sealing materials.

 **Temperatures**
from -60°C to +225°C

 **Pressures**
from 0,2 bar to 20 bar

 **Threaded connections**
from 3/8" to 2"



Data sheet

OVERFLOW AND PRESSURE CONTROL VALVES SERIES 453

made of stainless steel, angle-type with threaded connections



These overflow or control valves have been developed for complex applications with, for example, large overflow volumes, viscose media and counter pressures etc. With the stainless steel bellows that compensate counter pressures, a counter pressure affecting the outlet side does not influence the setting of the valve. The springs, designed precisely for the setting ranges, with the complex technical design of function parts in the flow range and the housing lead to the unusually high flow volumes for overflow valves despite the very proportional control reactions.

 **Temperatures**
from -60°C to +225°C

 **Pressures**
from 0,5 bar to 25 bar

 **Threaded connections**
from 1/2" to 2"



Data sheet

OVERFLOW AND PRESSURE CONTROL VALVES SERIES 853

made of gunmetal, angle-type, with threaded connections

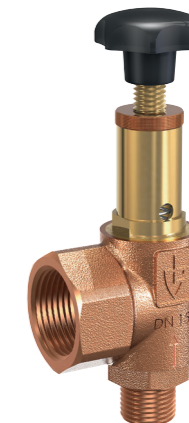

The alternative to the stainless steel version made of corrosion resistant gunmetal. Apart from the Media resistance of the housing material, the design is identical to the stainless steel series 453.

A suitable sealing material can be chosen for almost every Media. The valves can be set to the required pressure and sealed in the factory, or can be conveniently adjusted by the customer in the corresponding spring range using the hand wheel. The setting or adjustment can also be made during operation.

 **Temperatures**
from -60°C to +225°C

 **Pressures**
from 0,5 bar to 25 bar

 **Threaded connections**
from 1/2" to 2"



Data sheet

Overflow and pressure control valves

OVERFLOW AND PRESSURE CONTROL VALVES SERIES 430

made of stainless steel, straightway form, with threaded connections



This diaphragm-controlled overflow valve allows high flow rates at low differential pressure. In its closed, gastight version it is suitable for liquid and gaseous media. Fitted with Viton seals, its range of applications is extended so that it is suitable for media such as oil, petrol, kerosine or oil-laden compressed air.

Extremely service-friendly due to replacement valve cartridge. The set pressure can easily be read-off the (optional) pressure gauge.

Optionally available with female thread.

OVERFLOW AND PRESSURE CONTROL VALVES SERIES 431

made of stainless steel, straightway form, with flange connections

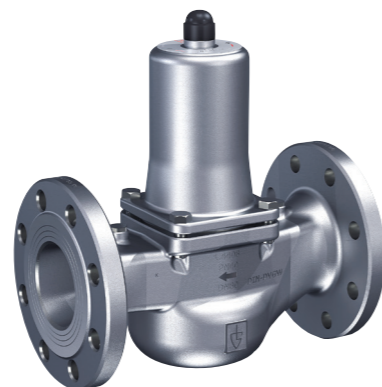

High flow rates at low differential pressures. Can be adjusted and set externally during operation, for liquid and gaseous media, service friendly due to replacement cartridge.

This overflow valve made of high-alloyed stainless steel combines all of these advantages. According to the sealing- and diaphragm materials employed, these valves can be used for neutral and non-neutral media.

 **Temperatures**
from -20°C to +120°C

 **Pressures**
from 0,5 bar to 10 bar

 **Threaded connections**
from 1/2" to 2"



Data sheet

 **Temperatures**
from -20°C to +120°C

 **Pressures**
from 0,5 bar to 10 bar

 **Flange connections**
from DN 15 to DN 100



Data sheet

OVERFLOW AND PRESSURE CONTROL VALVES SERIES 630

made of gunmetal, straightway form, with threaded connections

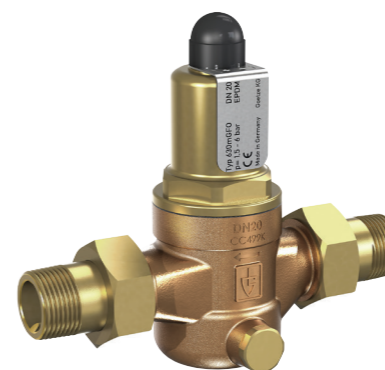

The alternative to stainless steel made of corrosion-resistant gunmetal.

The advantages of an external adjustment possibility during operation, high flow rates at low differential pressures, suitability for liquid and gaseous media. Easy service due to the replacement valve cartridge make this diaphragm-controlled overflow valve suitable for a wide range of applications.

Optionally available with female thread.

 **Temperatures**
from -20°C to +120°C

 **Pressures**
from 0,5 bar to 10 bar

 **Threaded connections**
from 1/2" to 2"



Data sheet

OVERFLOW AND PRESSURE CONTROL VALVES SERIES 631

made of gunmetal, straightway form, with flange connections



In cases where flange connections are required, this valve offers the same technical features as the 630 version of the overflow valve. The robust all-metal design makes these overflow valves ideal for harsh operating and environmental conditions when sensitive control is required. The set pressure can easily be read off the (optional) pressure gauge.

The valve is used to protect pumps in closed circuits against overloading as well as for control purposes in pressure systems for air, neutral/non-neutral gases and technical vapours.

 **Temperatures**
from -20°C to +120°C

 **Pressures**
from 0,5 bar to 10 bar

 **Flange connections**
from DN 15 to DN 100



Data sheet

SAFETY FITTINGS FOR HYGIENIC APPLICATIONS

Materials



Temperatures
from -40 °C to +200 °C



Pressures
from 0,4 bar to 16 bar

Media



Clamp connections
from DN 20 to DN 100

These valves are characterised by the particularly smooth, fault-free surfaces. This makes them perfect for cleaning. Our engineers also made sure there were no gaps when constructing these valves: whether it be at the valve inlet or when fixing all elastomere parts.

SAFETY FITTINGS FOR HYGIENIC APPLICATIONS ARE USED HERE:



Pharmaceutical



Brewery



Food Industry



Beverage Industry

Safety fittings for hygienic applications

SAFETY VALVES SERIES 400

made of stainless steel, angle-type
with clamp connections and food connections

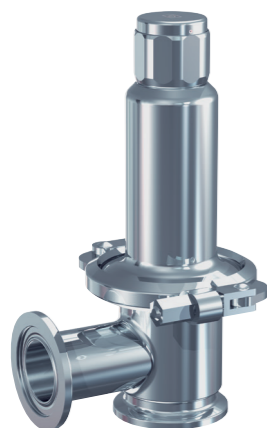

The valves in the Goetze Hygienic series are constructed in compliance with the construction features of hygienic design.

This includes smooth, fault-free and optimal surfaces for cleaning, minimum dead space, no gaps and lots of other details. Difficult to clean components are protected against impurities with stainless steel bellows.

The fulfilment of these construction features are proven and confirmed by tests and certificates from the DGUV Committee for Foods and Luxury Items and the EHEDG (European Hygienic Engineering & Design Group). The safety valves are approved for worldwide use in accordance with numerous regulations.

OVERFLOW / PRESSURE CONTROL VALVES SERIES 400.5

made of stainless steel, angle-type
with clamp connections and food connections



Just like the hygienic safety valves, these overflow/control valves are also implemented in line with the construction features of hygienic design and confirmed in tests by the DGUV Committee for Foods and Luxury Items.

Depending on the use and media, the seals are available with approvals in accordance with FDA, USP, 3-A and ADI-FREE.

The valves are particularly used to control processes and systems in the food and pharmaceutical industries. Suitability of the Media ranges from air to various neutral and non-neutral vapours, gases and liquids.

SAFETY VALVES SERIES 4000

made of stainless steel, angle-type
with stainless steel spring



In the sector of hygienic applications or clean service applications, very high requirements are applied on optimal cleanability and dead space free construction of equipment parts. At the development of the new safety valve series 4000, ranging from DN 25 to DN 100, these exact principles have been fulfilled and therefore exist in a safety valve for the first time. By using a conical diaphragm instead of a rubber flange, the area affected by the Media is optimally separated from the spring housing. On all surfaces, the primary conical valve seal and the housing seals, these principles have been fully implemented. Thus all surfaces are easy to clean.

For the lifting of the valves, additionally there is a pneumatic piston actuator and optionally a proximity switch for the display of the valve opening available.

In this totality, the requirements of the EHEDG and FDA in the sector of safety valves for hygienic or clean service applications are realized in a unique way.

 **Temperatures**
from -40 °C to +200 °C

 **Pressures**
from 0,4 bar to 16 bar

 **Clamp connections**
from DN 20 to DN 32



Data sheet

 **Temperatures**
from -40 °C to +200 °C

 **Pressures**
from 0,4 bar to 16 bar

 **Clamp connections**
from DN 20 to DN 32



Data sheet

 **Temperatures**
from -40 °C to +200 °C

 **Pressures**
from 0,4 bar to 16 bar

 **Clamp connections**
from DN 25 to DN 100



Data sheet







The hygienic cleaning process

Hygiene is an omnipresent theme, especially in the area of food and beverage processing. Particularly high demands are made of the surfaces coming into contact with the medium. This is why a dead space-free construction of equipment parts is essential.





PRESSURE REDUCING VALVES

Materials 	Temperatures  from -40°C to +120 °C	Inlet pressure to 60 bar Outlet pressure adjustable 
Media 	Threaded connections  from ¼" to 2"	Flange connections  from DN 15 to DN 100

Pressure reducing valves from the Goetze KG are available in a wide range of sizes, in order to offer the right solution for a wide variety of applications and connection types. Whether stainless steel or gunmetal in all-metal design. Flange- or threaded connection, you will find that we can offer you the optimum combination for your application.

PRESSURE REDUCING VALVES ARE USED HERE:

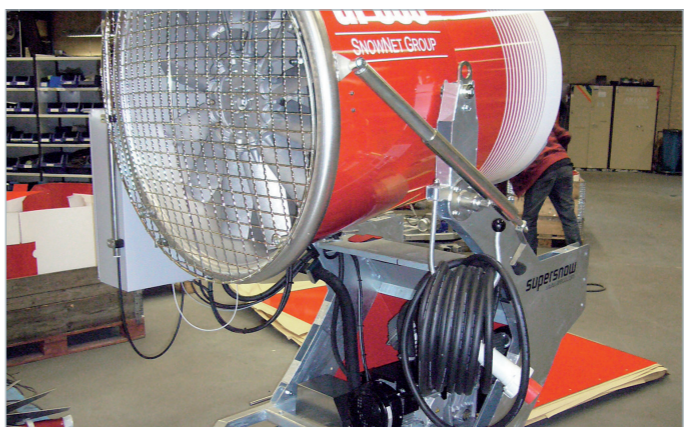

Snow-making equipment



Shipbuilding



Hydraulic control systems



Sprinkler systems

Pressure reducing valves

PRESSURE REDUCING VALVES SERIES 481 AND 681

made of stainless steel and gunmetal
with threaded connections

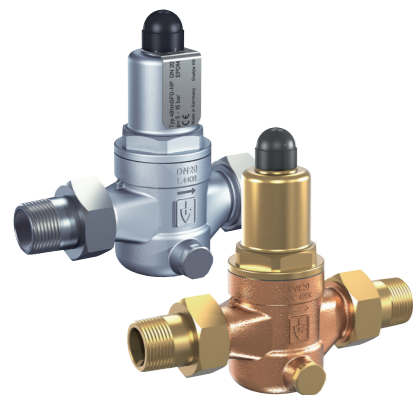

The proven, robust pressure reducing valves in full-metal-version with threaded connectors have not only proven themselves in drinking water application, but especially also in rough industrial operating conditions with many different, also aggressive substances and at fluctuating environmental temperatures. The materials used are optimised for water of different qualities and for warm water applications. Besides the standard range of adjustment of 1 to 8 bar the additional outlet pressure ranges of 0,5 bar to 2 bar and 5 bar to 15 bar cover a wide application range.

Optionally available with female thread.

 **Temperatures**
from -20°C to +120°C

 **Inlet pressure** up to 40 bar,
Outlet pressure adjustable
from 0,5 bar to 15 bar

 **Threaded connections**
from ½" to 2"



Data sheet



Data sheet

PRESSURE REDUCING VALVES SERIES 482 AND 682

made of stainless steel and gunmetal
with flange connections

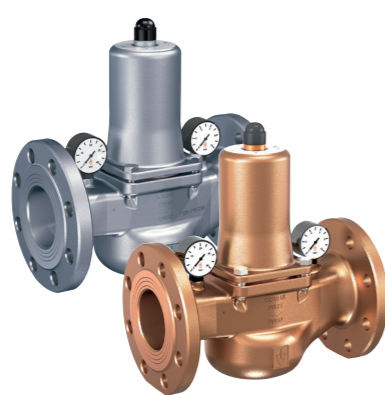

Fittings often require flange connections. This is the exact reason for our series in the nominal diameter ranges of DN 15 up to DN 100. Besides the standard versions of these pressure reducing valves made of stainless steel and gunmetal, the valves are also available in nominal diameters from DN 20 to DN 50 in high-pressure and a low-pressure version. Upon request we can also equip the stainless steel pressure reducing valves for various pressure ranges with stainless steel pressure gauges.

For highest service-friendliness also in the case of the flange versions, a replacement internal cartridge with integrated dirt trap is available.

 **Temperatures**
from -20°C to +120°C

 **Inlet pressure** up to 40 bar,
Outlet pressure adjustable
from 0,5 bar to 15 bar

 **Flange connections**
from DN 15 to DN 100



Data sheet



Data sheet

PRESSURE REDUCING VALVES SERIES 683

made of gunmetal, with
female threaded connections

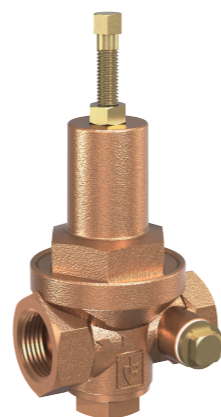

This pressure reducing valve is an alternative to the larger versions, in cases where only small flow volumes are required or the media in question is compressed air. With an outlet pressure of max. 50 bar the pressure reducing valve is used, for example, to control the starter air on ships. It goes without saying, that it holds all the necessary marine approvals of the various bodies such as Germanischer Lloyd etc.

This valve is used in many industrial applications particularly for compressed air and neutral gases.

 **Temperatures**
from -10°C to +95°C

 **Inlet pressure** up to 50 bar,
Outlet pressure adjustable
from 1,5 bar to 10 bar

 **Threaded connections**
from ⅜" to 1 ¼"



Data sheet

PRESSURE REDUCING VALVES SERIES 484

made of stainless steel, with
female threaded connections



These diaphragm and piston pressure reducing valves made of stainless steel and with female threaded connections for pneumatic and hydraulic applications are distinguished particularly by high flow rates and low pressure losses even in situations of high performance demands.

Their extremely precise control characteristics, the inlet pressure of up to 60 bar and the wide outlet pressure range make these pressure reducing valves the optimal solution for almost all technically demanding applications.

 **Temperatures**
from -40°C to +120°C

 **Inlet pressure** up to 60 bar,
Outlet pressure adjustable
from 0,5 bar to 50 bar

 **Threaded connections**
from ¼" to 2"



Data sheet

PRESSURE REDUCING VALVES SERIES 684

made of gunmetal, with
female threaded connections



All characteristics and technical features of the stainless steel versions also apply to the series 684 made of corrosion-resistant gunmetal. The fully relieved valves which therefore even out inlet pressure variations are available with and without secondary venting and each in a diaphragm or a piston version. Pressure adjustment is carried out without tools via the ergonomically formed hand-wheel.

The extremely small pressure loss in the pressure adjusting area leads to these high-performance pressure reducing valves having almost no competition.

 **Temperatures**
from -40°C to +120°C

 **Inlet pressure** up to 60 bar,
Outlet pressure adjustable
from 0,5 bar to 50 bar

 **Threaded connections**
from ¼" to 2"



Data sheet

VACUUM AND AIR VALVES

Vacuum and air valves

VENT VALVES TYPE 1940/45

made of stainless steel
with threaded connection



This is a vent valve for pipelines, pipeline systems, vessels and heat exchangers in which the pressure should not fall below the atmospheric pressure.

It is used for emptying vessels and protecting against vacuum build-up in tanks, pipelines, heat exchangers and vessels in steam plants.

VENT VALVES TYPE 1960/65

made of brass
with threaded connection



All characteristics and technical features of the stainless steel versions are the same in the series 1960/1965 made from gunmetal.

It is a vent valve for pipelines, pipeline systems, vessels and heat exchangers in which the pressure should not fall below the atmospheric pressure.

It is used for emptying vessels and protecting against vacuum build-up in tanks, pipelines, heat exchangers and vessels in steam plants.

 **Temperatures**
from -60°C to +225°C

 **Pressures**
from -6 mbar to -800 mbar

 **Threaded connection**
from ½" to 1"

 **Temperatures**
from -60°C to +225°C

 **Pressures**
from -6 mbar to -800 mbar

 **Threaded connection**
from ½" to 1"





Data sheet

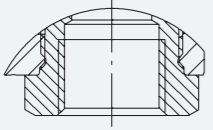
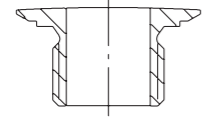
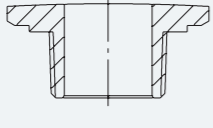
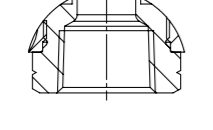
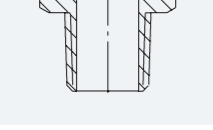
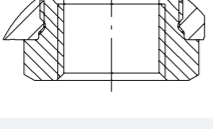
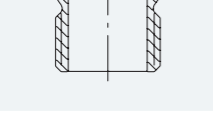
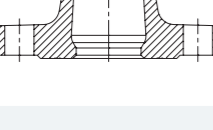
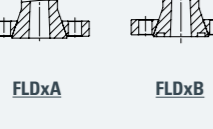

Data sheet

CONNECTION POSSIBILITIES

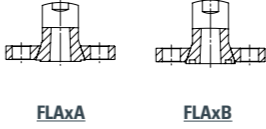
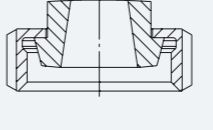
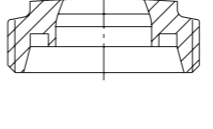
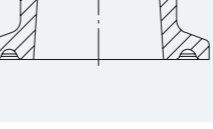
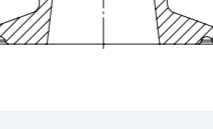
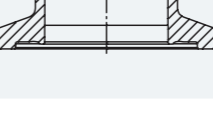
Connection type	Drawing	Description
f		Whitworth threaded cylindrical pipe connection – female – seal not made on thread BSP-P according to DIN ISO 228
m		Whitworth threaded cylindrical pipe connection – male – seal not made on thread BSP-P according to DIN ISO 228
BSP-Tm		Whitworth threaded tapered pipe connection – male – seal made on thread male connection BSP-T according to DIN EN 10226
NPTf		US standard tapered pipe thread NPT threaded pipe connection NPT – female – according to ANSI / ASME B 1.20.1 seal made on thread
NPTm		US standard tapered pipe thread NPT threaded pipe connection NPT – male – according to ANSI / ASME B 1.20.1 seal made on thread
METf		Metric ISO female connection according to DIN 13 seal not made on thread
METm		Metric ISO male connection according to DIN 13 seal not made on thread
FL		Cast flange connection according to DIN EN 1092
FLDxA, FLDxB		Loose flange connection according to DIN EN 1092 up to max. PN 100 x = Pressure rating A = Without sealing groove B = With sealing groove

Connection type	Drawing	Description
FLxA, FLxB		Loose flange connection according to ASME B 16.5 up to max. 600 lbs x = Pressure rating A = Without sealing groove B = With sealing groove
KSDIN		Taper nipple (diary coupling screw joint) according to DIN 11887 valves for food, chemical and pharmaceutical industry standard threaded connections
GSDIN		Threaded ferule connection – male – (diary coupling screw joint) according to DIN 11887 valves for food, chemical and pharmaceutical industry standard threaded connections
KLSDIN		Clamp connection according to DIN 32676 valves for food, chemical and pharmaceutical industry
KLISO		Clamp connection according to ISO 2852 valves for food, chemical and pharmaceutical industry
A-KLSDIN		Aseptic clamp ferrule connection DIN 11864-3 valves made of stainless steel for aseptic, chemical and pharmaceutical industry
A-GSDIN		Aseptic threaded ferule connection – male – form A DIN 11864-1 aseptic threaded pipe connection for the food, chemical and pharmaceutical industry

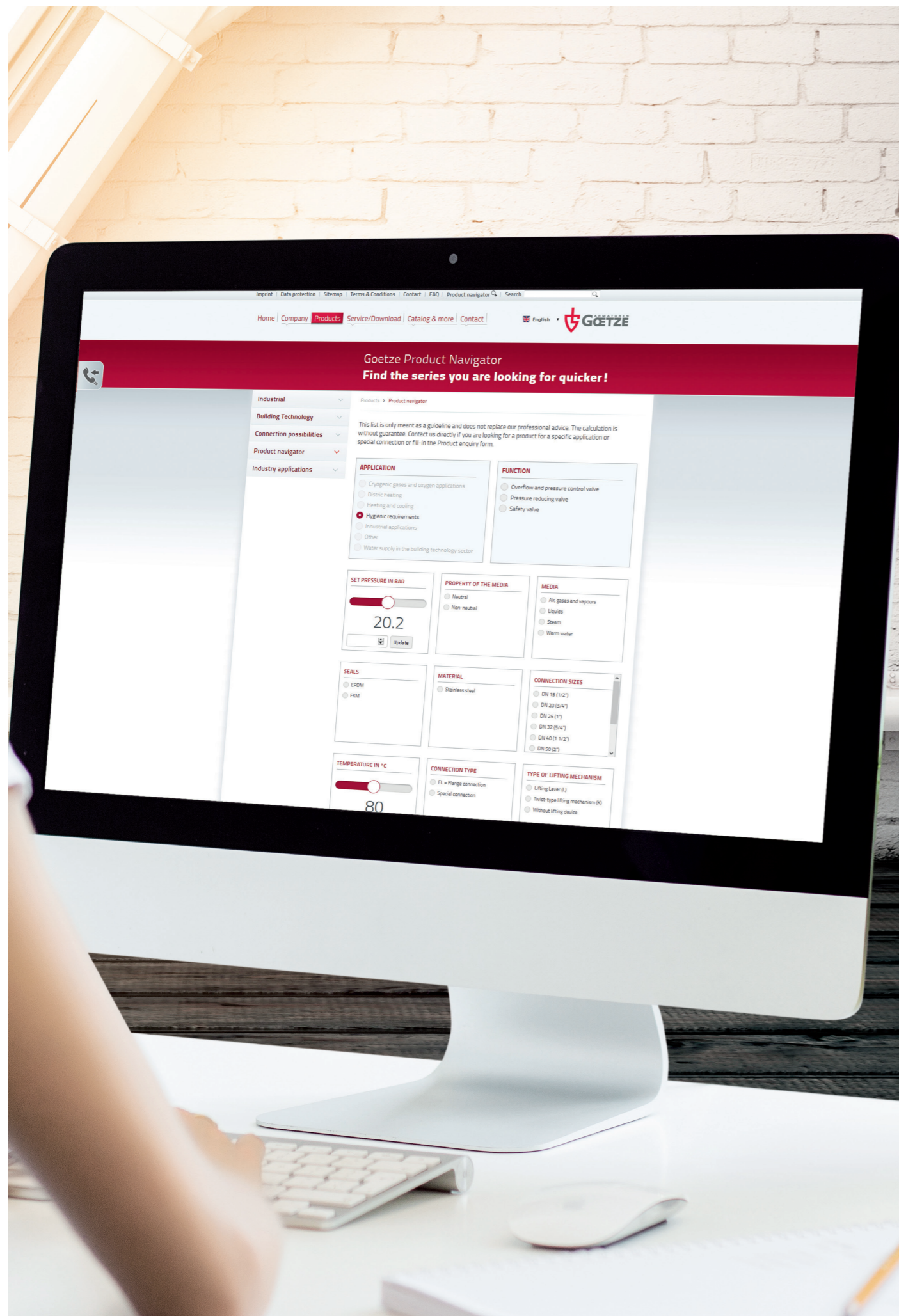

INTERNET SERVICE OF GOETZE

GOETZE PRODUCT NAVIGATOR

You want to find the series you are looking for quicker? Using the Goetze configurator, you can select the desired specifications and characteristics and will be shown a list of matching products. The navigator is for orientation purposes only and does not replace consultation with a technical expert. Give it a try and find the right product for your applications.

www.goetze-armaturen.com/navigator-en

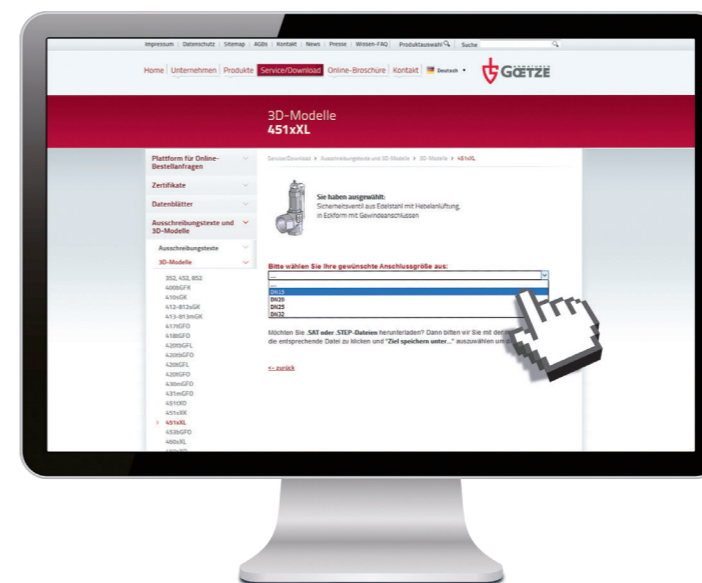

3D MODELS AND TENDER DOCUMENTS

For your planning and tenders, we voluntarily provide data of our 3D models in various and common formats. On our website, you will find them in the sector "Service/Download". Just request once your password and you will get immediate access to all relevant data. Beside the 3D models, we offer prefabricated tender documents that you may simply integrate in your offers.

Here is the link for your registration to the download of our tender documents and 3D models:

www.goetze-armaturen.com/service-en

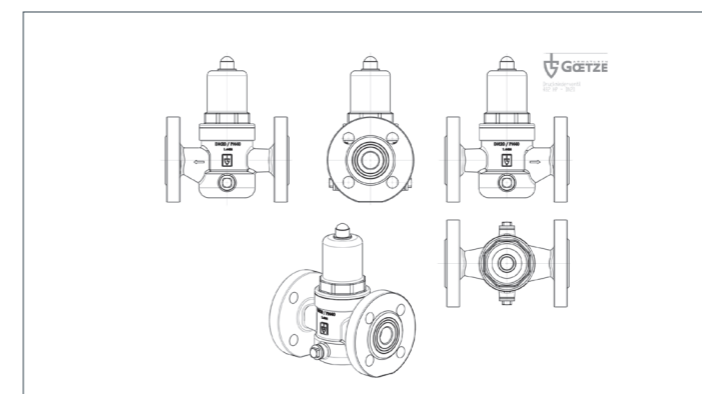

MOBILE WEBSITE

Our website is also available in a version optimised for smart phones. As usual, you may find your products simply and easily – also en route.

Curious? Just take a look!

www.goetze-armaturen.com



Goetze KG Armaturen

Robert-Mayer-Straße 21
71636 Ludwigsburg
Fon: +49 (0) 71 41 / 4 88 94 60
Fax: +49 (0) 71 41 / 4 88 94 88
info@goetze-armaturen.de
www.goetze-armaturen.com



Subject to technical modifications. All documents / contents have been produced with utmost care. However, we accept no liability arising from any printing errors, mistakes etc.